

PCL 50

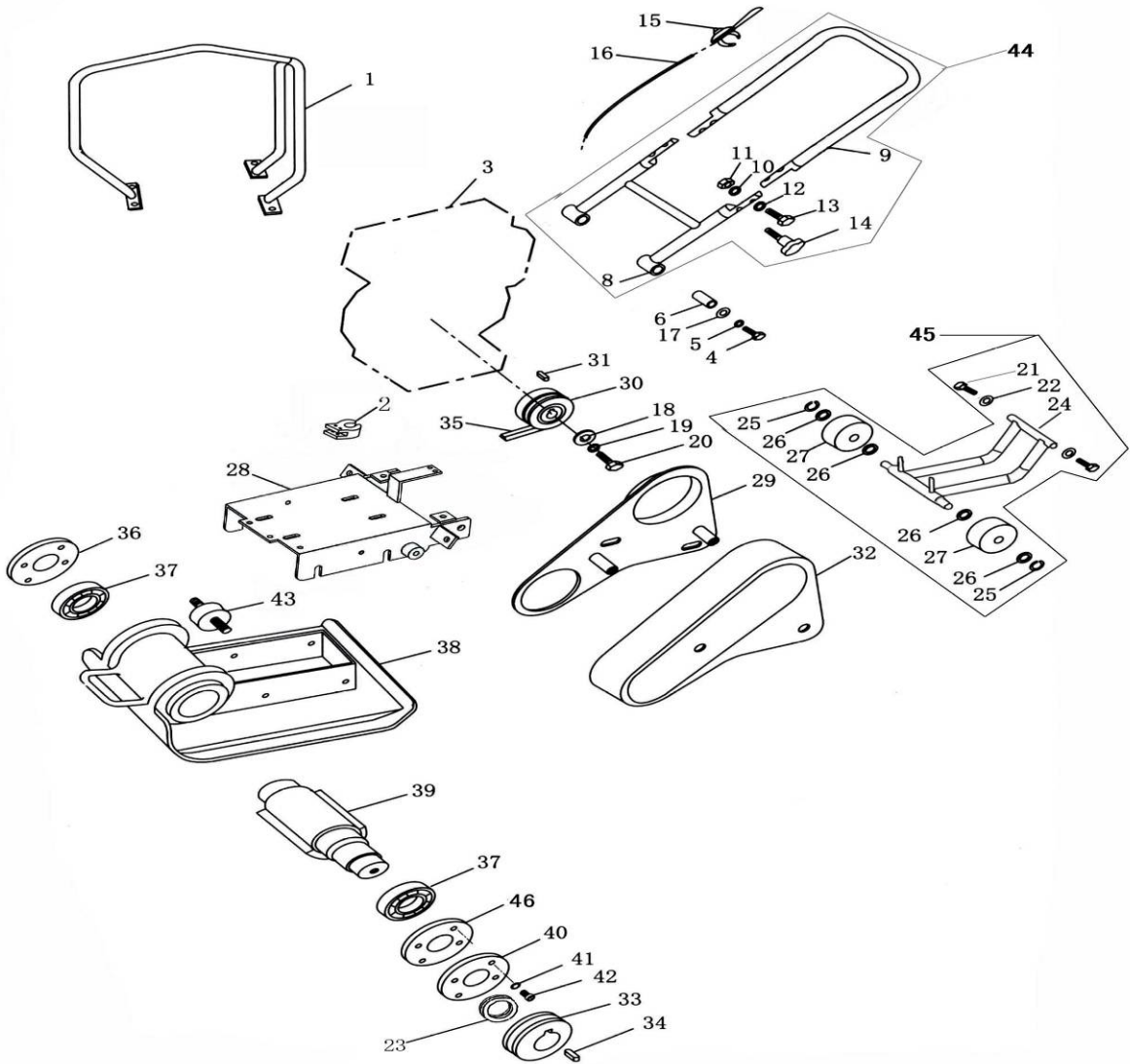

POS.	PART NO.	DESCRIPTION
1	500001	protective frame(Optional)
2	500002	Clamp
3	500003	Engine
4	500004	Hexagonal bolt M12*55
5	500005	Washer ϕ 12.5
6	500006	Rubber coupling
8	500008	the lower half of Handle (Optional)
9	500009	the upper half of Handle (Optional)
10	500010	Washer ϕ 10(Optional)
11	500011	locknut M10(Optional)
12	500012	Washer ϕ 10(Optional)
13	500013	Hexagonal bolt M10*35(Optional)
14	500014	Offset ring bolt(Optional)
15	500015	Throttle lever
16	500016	Dragline
17	500017	Washer ϕ 12
18	500018	Washer ϕ 8
19	500019	Spring washer ϕ 8
20	500020	Hexagonal bolt M8*25
21	500021	stranding screw M10*35(Optional)
22	500022	Washer ϕ 10(Optional)
23	500023	Oil seal

24	500024	bracket of trolley wheel(Optional)
25	500025	clamp spring ϕ 17(Optional)
26	500026	washer ϕ 17(Optional)
27	500027	wheel(Optional)
28	500028	Base
29	500029	dust-proof plate
30	500030	Clutch assembly
31	500031	flat key 5*30
32	500032	Belt cover
33	500033	Pulley, driven
34	500034	flat key 8*16
35	500035	V-belt
36	500036	Bearing cover / pulley
37	500037	Bearing 209
38	500038	Vibrating plate
39	500039	Ecc. Rotary shaft
40	500040	Cover seal, vib.
41	500041	spring washer ϕ 5
42	500042	Hexagonal bolt M6*25
43	500043	Shock absorber
44	500044	Foldable Handle(Optional)
		Straight Handle
45	500045	Trolley wheel Assy(Optional)
46	500046	paper cushion