

MODEL BV77 E

UNIT 1

ILLUSTRATED PARTS BREAKDOWN

From Serial Number: 30800001
Untill Serial Number: 31800559

Edizione 2010
Rev. A

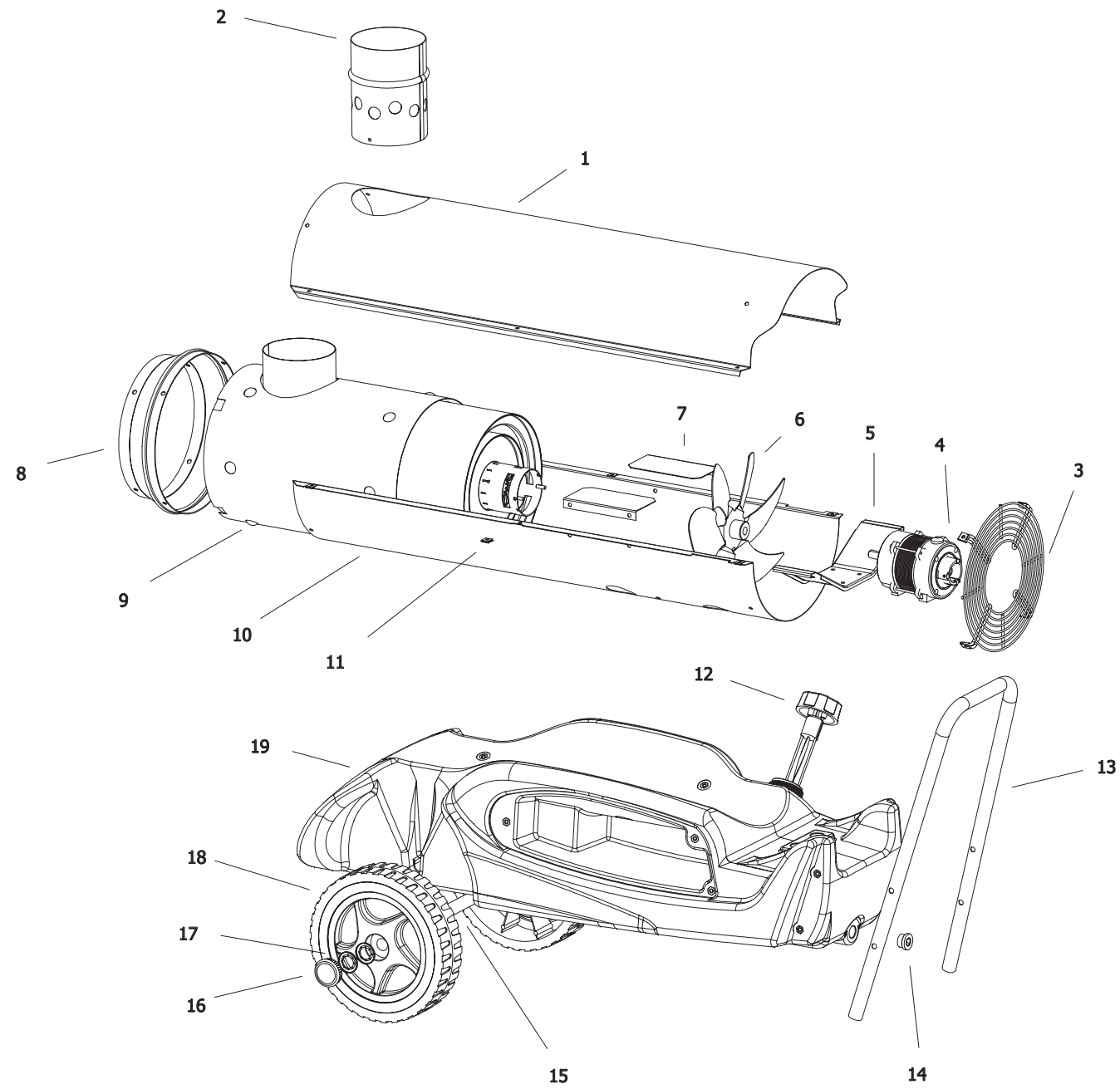

MODEL BV77 E

UNIT 2

ILLUSTRATED PARTS BREAKDOWN

From Serial Number: 30800001

Untill Serial Number: 31800559

Edizione 2010
Rev. A

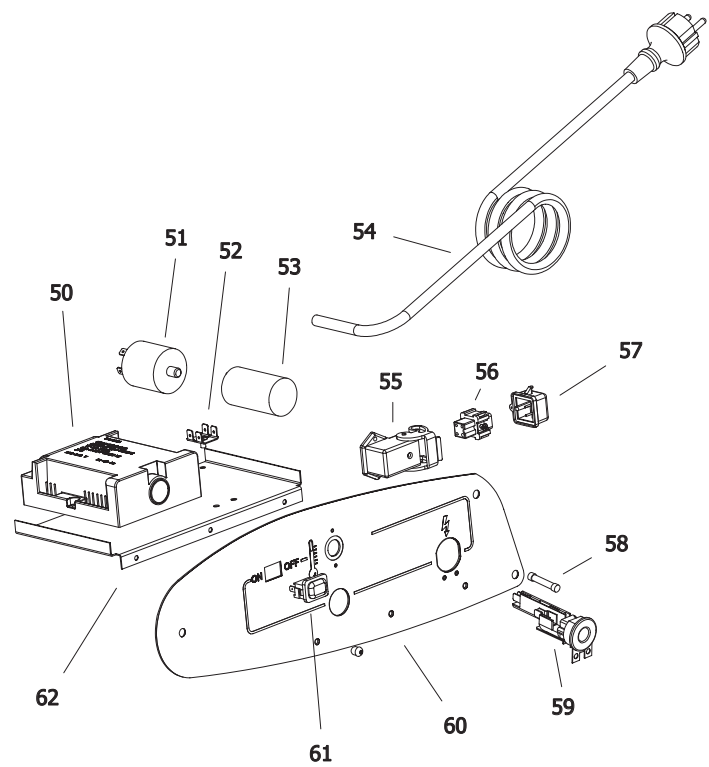
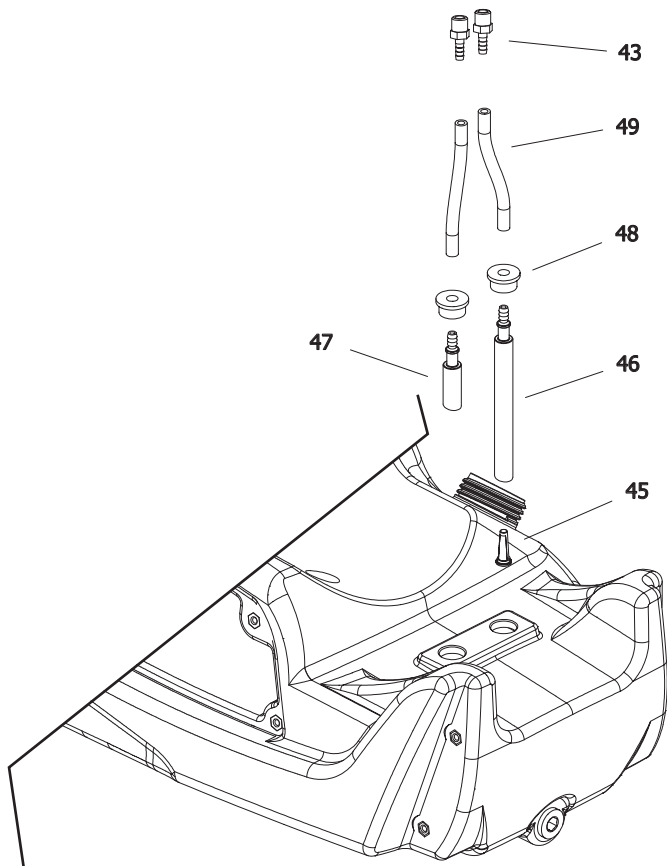
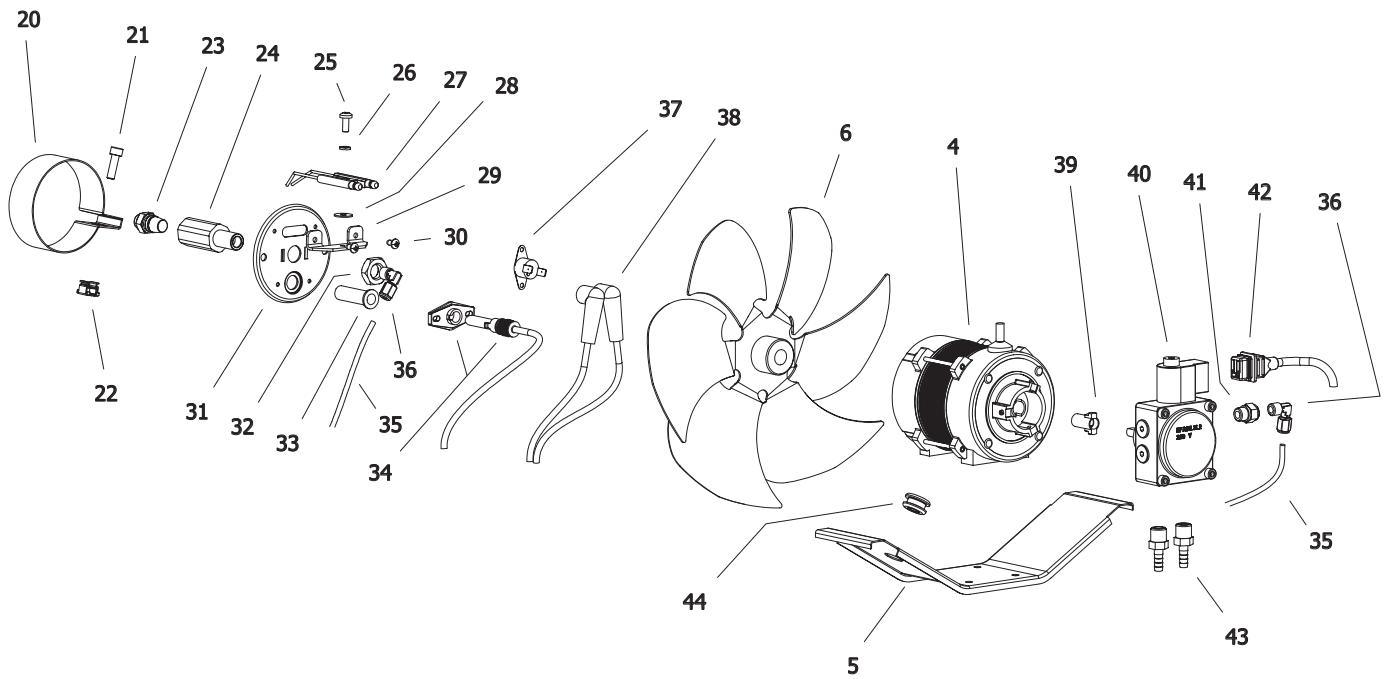

MODEL BV77 E

UNIT 3

PARTS LIST

Pos.	Code NR	Description	Rev. C - May 2012
1	4032.832	UPPER SHELL	
2	4032.387	CHIMNEY	
3	4032.836	GRID	
4	4032.815	MOTOR	
5	4032.835	MOTOR BRACKET	
6	4032.814	FAN	
7	4032.808	AIR FLAP	
8	4032.837	OUTLET AIR CONE	
9	4033.081	COMBUSTION CHAMBER	
10	4032.834	LOWER SHELL	
11	4104.170	CLIP NUT	
12	4032.978	FUEL LEVEL PROBE	
13	4032.386	HANDLES	
14	4032.813	DRAIN PLUG	
15	4032.389	AXLE	
16	4111.480	WHEEL PLUG	
17	4111.072	WHEEL HOLDER	
18	4032.094	WHEEL	
19	4033.037	TANK	
20	4032.545	AIR REGULATION FLAP	
21	4032.455	SCREW	
22	4032.454	CAGE NUT	
23	4031.536	NOZZLE	
24	4110.363	SCREW	
25	4110.393	WASHER	
26	4033.123	BIFILAR ELECTRODE	
27	4033.042	BURNER FLANGE	
28	4033.022	PHOTOCELL	
29	4033.187	OIL SUPPLY PIPE	
30	4033.198	ELBOW	
31	4032.883	LIMIT THERMOSTAT	
32	4031.048	HT CABLE	
33	4111.081	COUPLING	
34	4032.789	PUMP	
35	4161.501	NIPPLES	
36	4032.905	POWER CORD SOLENOID SPOOL	
37	4032.906	FITTING 1/4"	
38	4032.947	CABLE PROTECTION	
39	4110.356	FUEL FILTER	
40	4110.355	FUEL LINE TANK-PUMP	
41	4033.038	FUEL PIPE PUMP-TANK	
42	4100.541	RUBBER BUSHING	
43	4110.032	FUEL LINE	
44	4033.017	IGNITION CONTROL ASSEMBLY	
45	4032.771	POWER LINE RFI FILTER	
46	4160.639	POP RIVET WITH TERMIN. 4 WAY	
47	4032.816	CAPACITOR 6,3 μ f	
48	4111.153	POWER CORD	
49	4160.647	PLATE PLUG	
50	4161.400	CONNECTION SOCKET	
51	4162.467	THERMOSTAT PLUG	
52	4032.850	FUSE (6,3X32) 15A	

ESP00121

52	4160.639	POP RIVET WITH TERMIN. 4 WAY
53	4032.816	CAPACITOR 6,3 μ f
54	4111.153	POWER CORD
55	4160.647	PLATE PLUG
56	4161.400	CONNECTION SOCKET
57	4162.467	THERMOSTAT PLUG
58	4032.850	FUSE (6,3X32) 15A
59	4111.038	STRAIN RELIEF
60	4032.823	ELECTR. COMPONENTS PANEL
61	4100.667	ON/OFF SWITCH
62	4032.897	ELECTR. COMPONENTS BASE

S/R - Parts available by special request only